

ProTran Technology

DualPower ProLight Voltage Awareness Device

MODEL# 0011

DESCRIPTION

The ProTran DualPower ProLight gives extra reliability and redundancy. The DualPower ProLight indicates the presence of dangerous DC Voltage on a Light rail, Subway and Third Rail line. Simply connect the light as instructed and the unit will alert personnel of dangerous DC voltage from 50VDC to 1000VDC.

APPROVALS OR TESTED:

United States	U.L. Listed Components
Europe	RoHS/WEEE/GREEN



APPLICATIONS

The DualPower ProLight should be installed on or near overhead doors, DC switches, stinger systems, overhead contact wire, third rail, tunnels, anywhere indication of live and dead power is required.

24 hour battery back-up available upon request.

SPECIFICATIONS

LED	80-250 EXTRA BRIGHT LEDs
LED Colors	Red, Green
Power Requirements	50-1000VDC Max
Polar Sensitive	NO
Redundancies	5 Main Boards – 10 groups of LEDs
Options	Alarm, Meter, Fuse upon request
Enclosure	Polycarbonate
Output	Less then 1/3 Amp (300 Ma)
Rotating / Flashing	Rotating / Flashing upon request

Note: specifications shown are for all models sold after the printed document date shown below on each bulletin.

ProTran Technology

DOCUMENT DATE 08-FEB-12

P.O. Box 659, Flanders, NJ 07836
 Phone 609-704-1737 Fax 609-704-0565
protran@protrantechnology.com
www.protrantechnology.com

PRODUCT INFORMATION BULLETIN



DualPower ProLight

DIMENSIONS

10" x 7" x 12" / 15.87cm x 25.4cm x 17.78cm
 8 lbs / 3.62kg

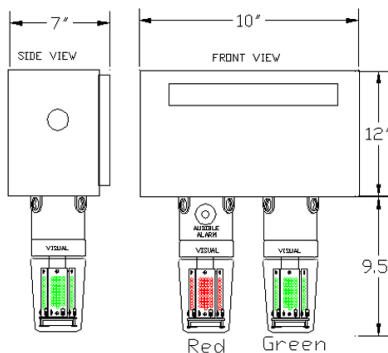

LIMITED WARRANTY STATEMENT

ProTran- branded products purchased in the U.S. or Europe come with a limited warranty; if properly used and installed, will be free from defects in material and workmanship for a period of 1-year after date of purchase. The warranty period is not extended if we repair or replace a warranted product or any parts. Said warranty to include the repair or replacement of defective equipment.

What is not covered by this limited warranty?

This limited warranty does not cover:
 Damage due to external causes, including accident, problems with electrical power, and usage not in accordance with product instructions, misuse, neglect, alteration, repair, improper installation, or improper testing.

THIS LIMITED WARRANTY, AND ANY IMPLIED WARRANTIES THAT MAY EXIST UNDER STATE LAW, APPLY ONLY TO THE ORIGINAL PURCHASER OF THE EQUIPMENT, AND LAST ONLY FOR AS LONG AS SUCH PURCHASER CONTINUES TO OWN THE EQUIPMENT. THIS WARRANTY REPLACES ALL OTHER WARRANTIES, EXPRESS OR IMPLIED INCLUDING, BUT NOT LIMITED TO, THE IMPLIED WARRANTIES OR MERCHANTABILITY AND FITNESS FOR A PARTICULAR PURPOSE. ProTran MAKES NO EXPRESS WARRANTIES BEYOND THOSE STATED HERE. ProTran DISCLAIMS WITHOUT LIMITATION, IMPLIED WARRANTIES OF MERCHANTABILITY AND FITNESS FOR A PARTICULAR PURPOSE. SOME JURISDICTIONS DO NOT ALLOW THE EXCLUSION OF IMPLIED WARRANTIES SO THIS LIMITATION MAY NOT APPLY TO YOU.

TO OBTAIN WARRANTY SERVICE, CONTACT ProTran FOR A RETURN MATERIAL AUTHORIZATION. WHEN RETURNING EQUIPMENT TO ProTran, THE CUSTOMER ASSUMES THE RISK OF DAMAGE OR LOSS DURING SHIPPING AND IS RESPONSIBLE FOR THE SHIPPING COSTS INCURRED.